Prestige Gas Vent Stainless Termination Kit



Kit Part Number:

PSVKIT01

3 Inch Vent System Termination

PSVKIT02

4 Inch Vent System Termination

Recommended tools:

- Phillips Screwdriver
- Core Drill or Hole Saw

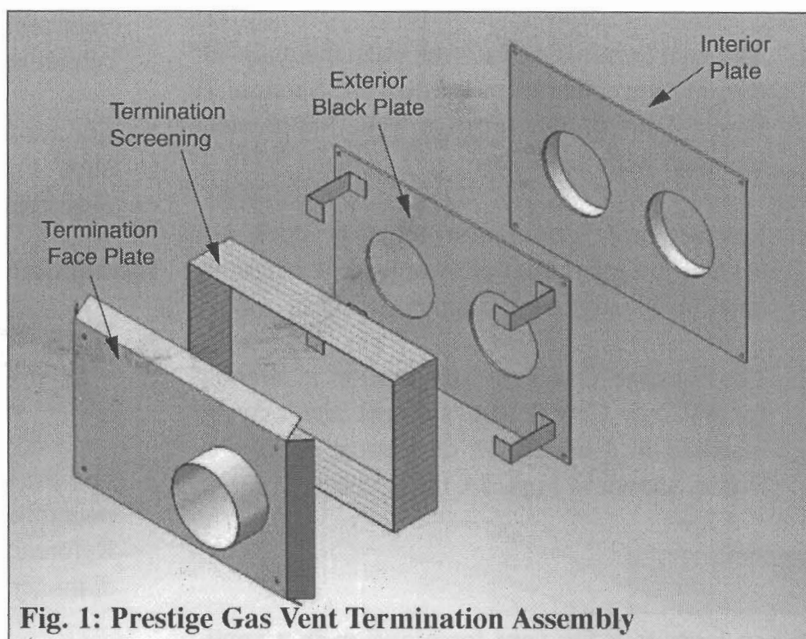

Fig. 1: Prestige Gas Vent Termination Assembly

WARNING

Indicates a potentially hazardous situation which, if ignored, can result in serious injury or substantial property damage.

NOTICE

Indicates special instructions on installation, operation or maintenance, which are important to equipment but not related to personal injury hazards.

WARNING

Failure to follow instructions below can result in severe personal injury or damage if ignored.

- Instructions are for a qualified installer/service technician.
- Read all instructions before proceeding.
- Follow instructions in proper order.

Prestige Gas Vent Stainless Termination Kit

Pre-Installation Guidelines

1. The vent termination location must maintain all termination clearances stated in Section II Direct Vent of the Prestige Vent Supplement included with the boiler.
2. Ensure vent termination location does not exceed the maximum allowable vent length as listed in Prestige Vent Supplement.
3. The Prestige Gas Vent Termination is suitable for PVC or CPVC vent systems and may be installed in a horizontal or vertical configuration as shown in Figs. 5A through 6B.

NOTICE

When installing the vent termination in a vertical configuration, ensure the vent piping is located above the air inlet piping. This will reduce the risk of flue gas products recirculating into the air inlet.

NOTICE

For installations in Canada, all piping, fittings and cement/primer material must comply with CSA or ULC certification.

NOTICE

Do not use cellular core piping for the venting system.

WARNING

DO NOT mix vent components from different vent systems. Use only PVC or CPVC pipe and fittings. Seal all pipe and fittings with appropriate primer and cement. Failure to comply with these requirements could cause venting system failure resulting in leakage of flue products into the living space.

4. All vent piping and assembly / gluing of the vent piping should comply with the guidelines referenced in the Prestige Vent Supplement.
5. For multiple vent termination installation, reference Figure 5 for vertical installations and Figure 6 for horizontal installations.

Installation of the Vent Termination

1. Disassemble the termination plates as shown in Figure 1. Do not discard any of the mounting screws used in securing the assembly.
2. Use the interior plate as a template to locate the penetration holes through the outside wall. Reference Table 1 below for the proper hole diameter.
3. Use a core drill or hole saw to cut the penetration holes through the outside wall.

Table 1

Pipe Size	Vent Pipe Hole Size	Air Pipe Hole Size
3" PVC	4"	3.5"
4" PVC	5"	4.5"

NOTICE

The above table listing the require hole size for the vent and air pipe includes the require clearances to combustibles. The termination kit does not require a wall thimble, so these clearances to combustible must be maintained.

4. Fasten the interior plate to the interior face of the building wall using the pre-drilled mounting holes and the #10 x 3/4" mounting screws.
5. Install the air intake piping and the vent piping through the penetration holes. Ensure the air intake piping extends beyond the exterior face of the wall 1" and the vent piping extends 2" beyond the exterior face of the wall. Tighten

Prestige Gas Vent Stainless Termination Kit

the support bands on the interior plate to support the piping. See Figure 2 and Figure 3.

6. Mount the exterior back plate over the protruding vent and air intake piping. Use the supplied #10 x 1" mounting screws to secure the plate to the exterior face of the building as shown in Figure 3.
7. Apply a bead of high temp silicone (RTV) around the vent and air intake piping where it penetrates through the exterior back plate as shown in Figure 3.
8. Apply a generous bead of high temperature silicone (RTV) along the outside circumference of the vent pipe as shown in Figure 3.
9. Install the termination screening onto the exterior back plate as shown in Figure 4. Using a slight twisting motion install the termination faceplate with the vent pipe inserted into the vent coupling.

10. Using the mounting screws removed in STEP 1, secure the termination faceplate to the exterior back plate.

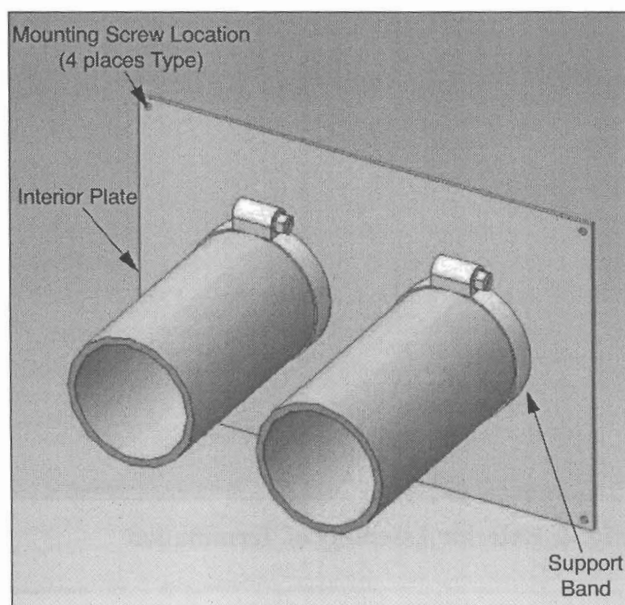

Fig. 2: Mounting of Interior Plate

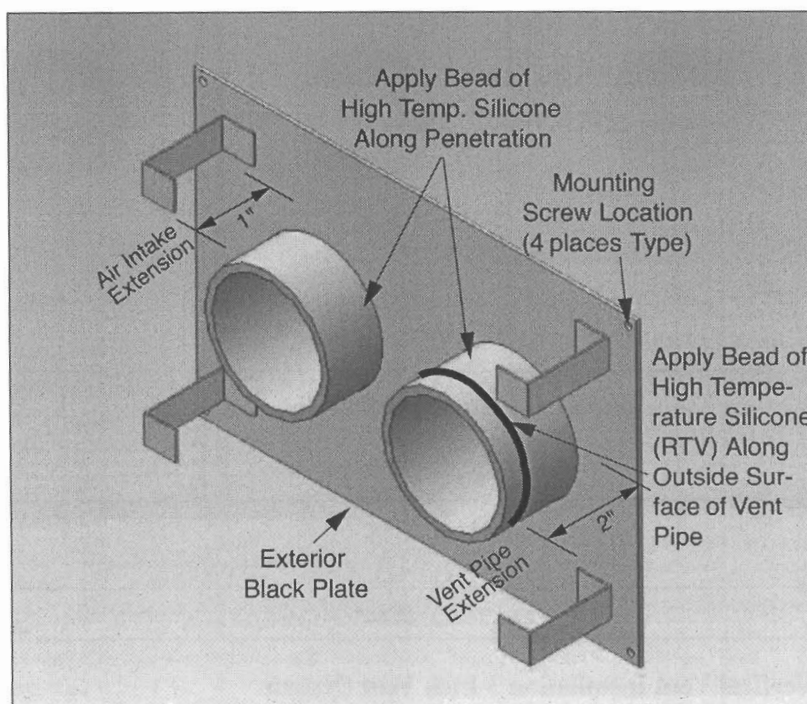

Fig. 3: Mounting of Exterior Back Plate

Prestige Gas Vent Stainless Termination Kit

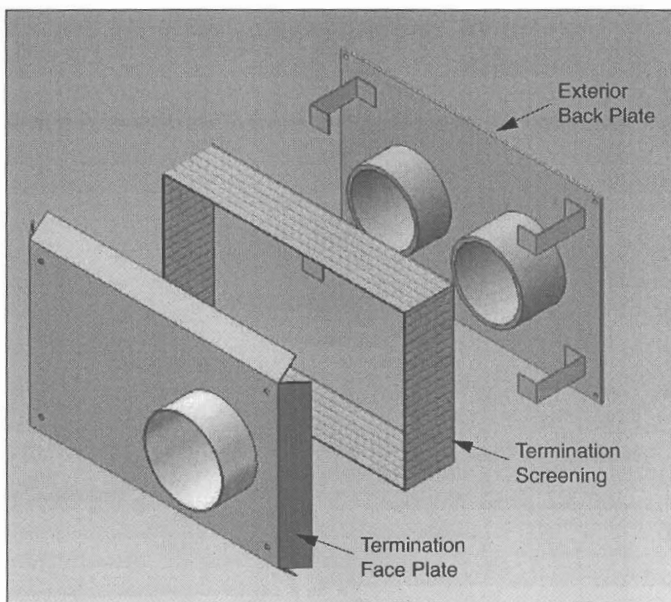

Fig. 4: Exterior Assembly of Termination

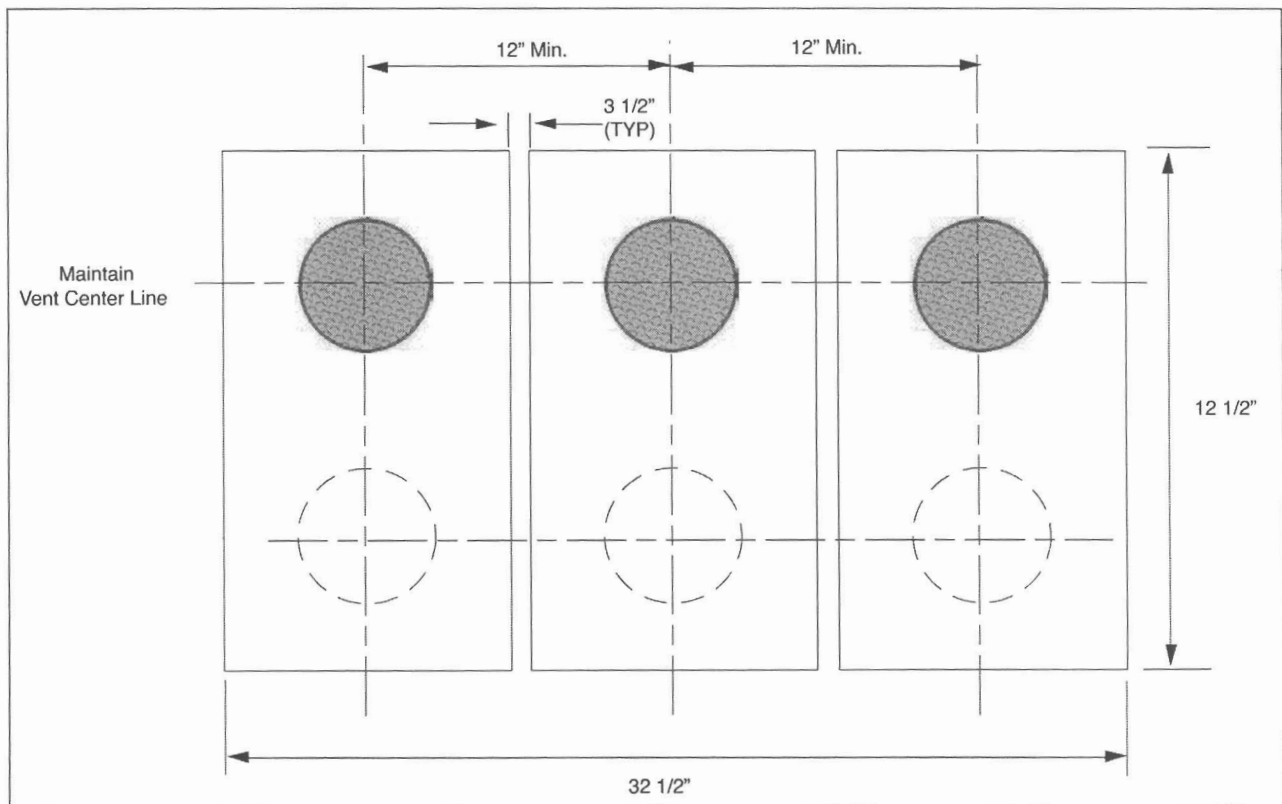

Fig. 5A: Multiple Vertical Vent Installation 3 Inch Vent System

Prestige Gas Vent Stainless Termination Kit

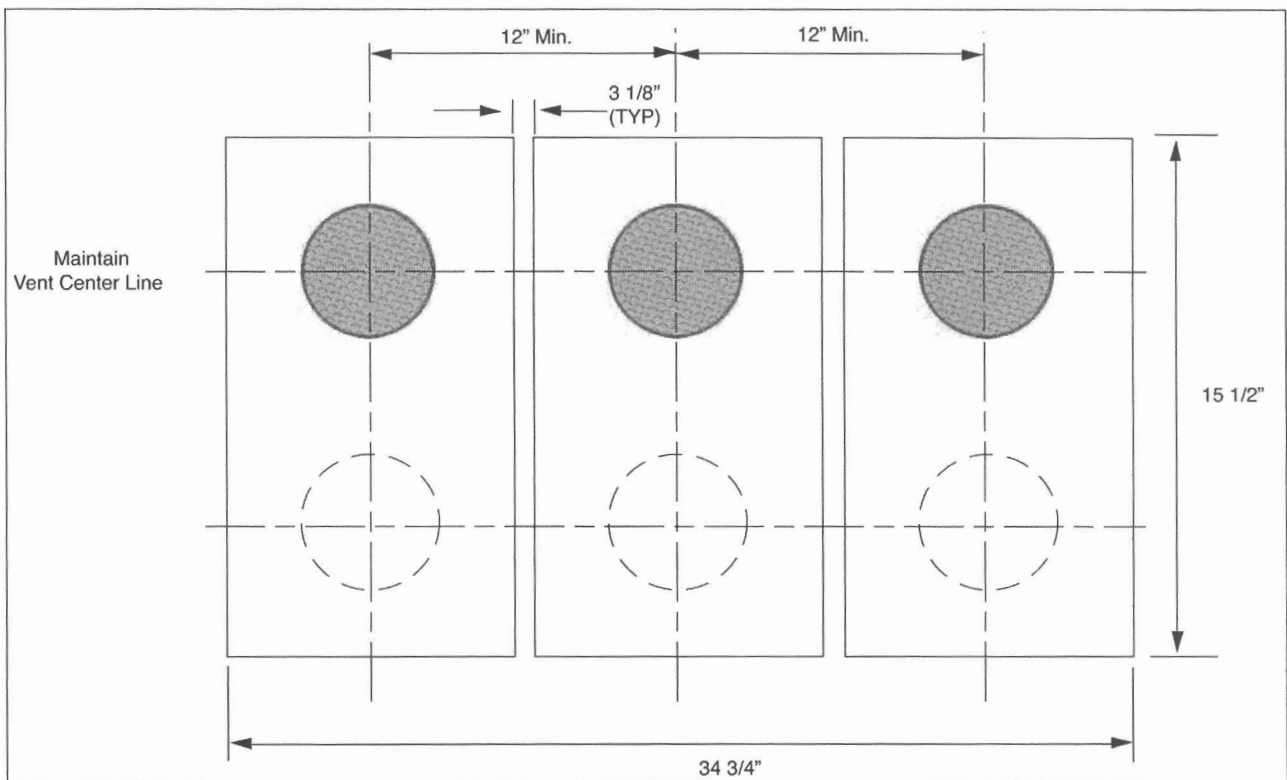

Fig. 5B: Multiple Vertical Vent Installation 4 Inch Venting System

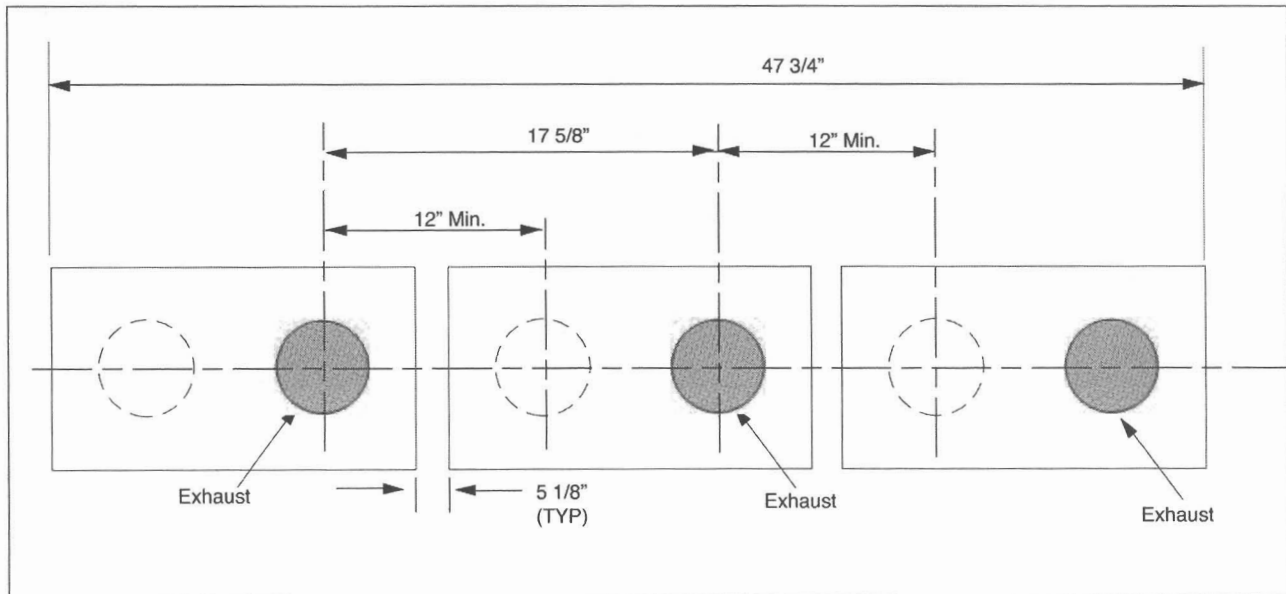

Fig. 6A: Multiple Horizontal Vent Installation 3 Inch Venting System

Prestige Gas Vent Stainless Termination Kit

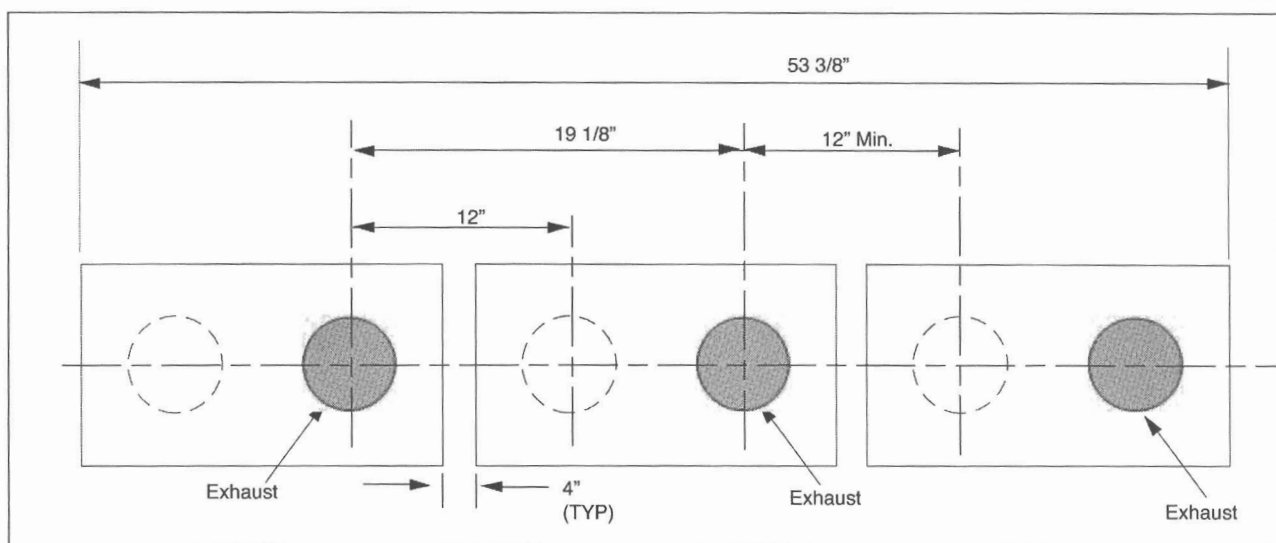

Fig. 6B: Multiple Vertical Vent Installation 4 Inch Venting System

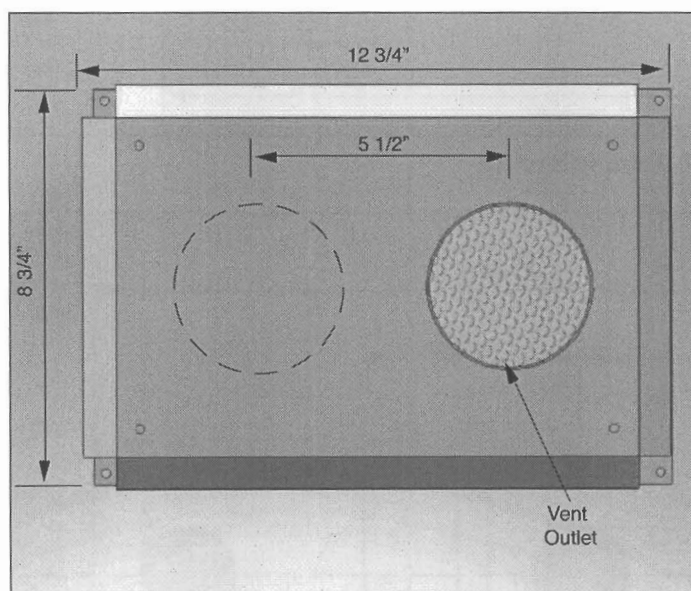

Fig. 7A: 3 Inch Vent Termination Dimensions

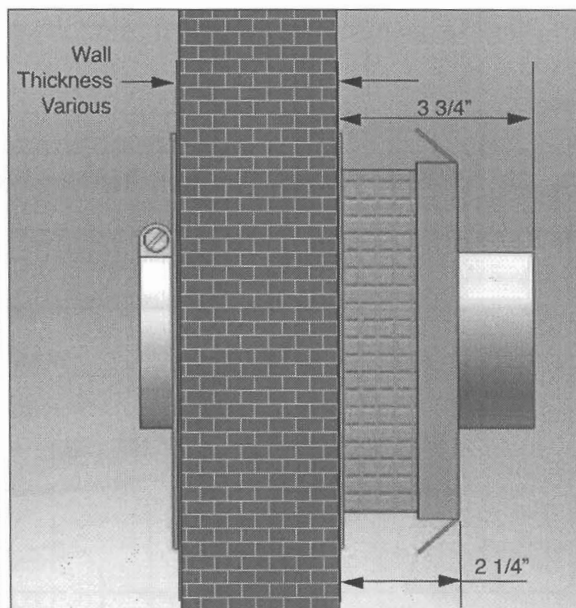

Fig. 7B: 3 Inch Vent Termination Dimensions

Prestige Gas Vent Stainless Termination Kit

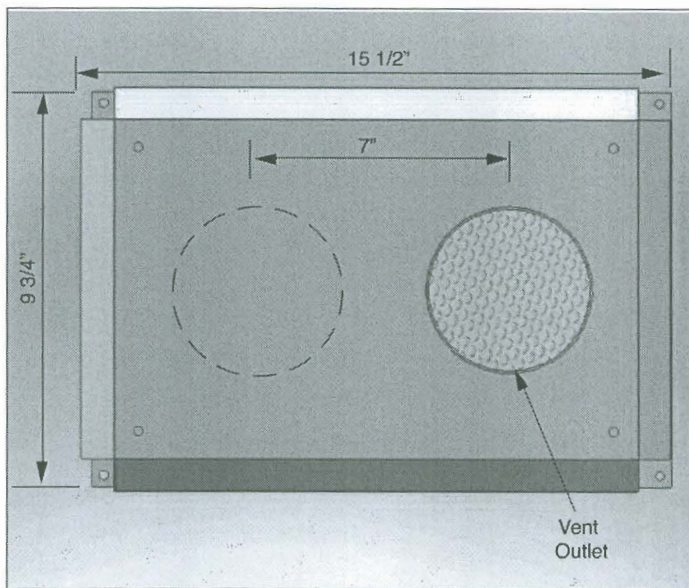

Fig. 8A: 4 Inch Vent Termination Dimensions

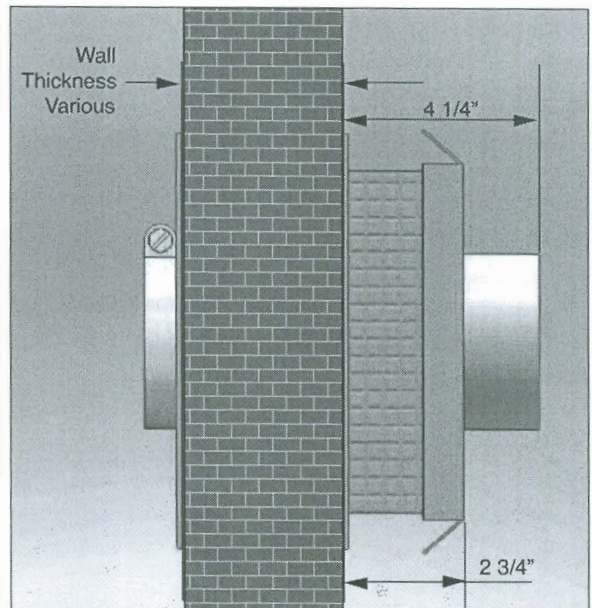

Fig. 8B: 4 Inch Vent Termination Dimensions